































 Railway industry		   
 Renewable energies		  
 Turbines		 
 Oil & Gas industry		   
 Steel and heavy duty industry		    
 General industry		   

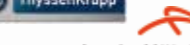

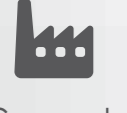
gurutzpe.com

HEADQUARTERS

GURUTZPE TURNING SOLUTIONS S.L.
Pol. Ind. Parcela Q8 ITZIAR-DEBA (SPAIN)
T +34 943 19 90 80
F +34 943 19 92 25
gurutzpe@gurutzpe.com

Gurutzpe China

北京昌平区北七家高科技工业园
电话: 0086-10-81764768-109
手机: 0086-13693033639
传真: 0086-10-81764595
邮箱: tc_wang@126.com

Gurutzpe USA

1270 Rankin, Suite E
Troy, MI 48063 USA
Phone: (815) 282 3310
Fax: (248) 733 9717
Cell: (815) 979 3758
skmach1@aol.com

Gurutzpe Rusia

Gurutzpe Россия
МариоФернандесМосква Ул
Мневники, д.З, строение1,
Тел: 8 910 421 28 13
gurutzpe.ru@gmail.com

Gurutzpe Germany

Gurutzpe Brasil

Gurutzpe India



right turning solutions

EUROPEAN LEADERS IN HEAVY DUTY CNC LATHES



TURNING SOLUTIONS FOR YOU.



Propuesta de solución de torneado

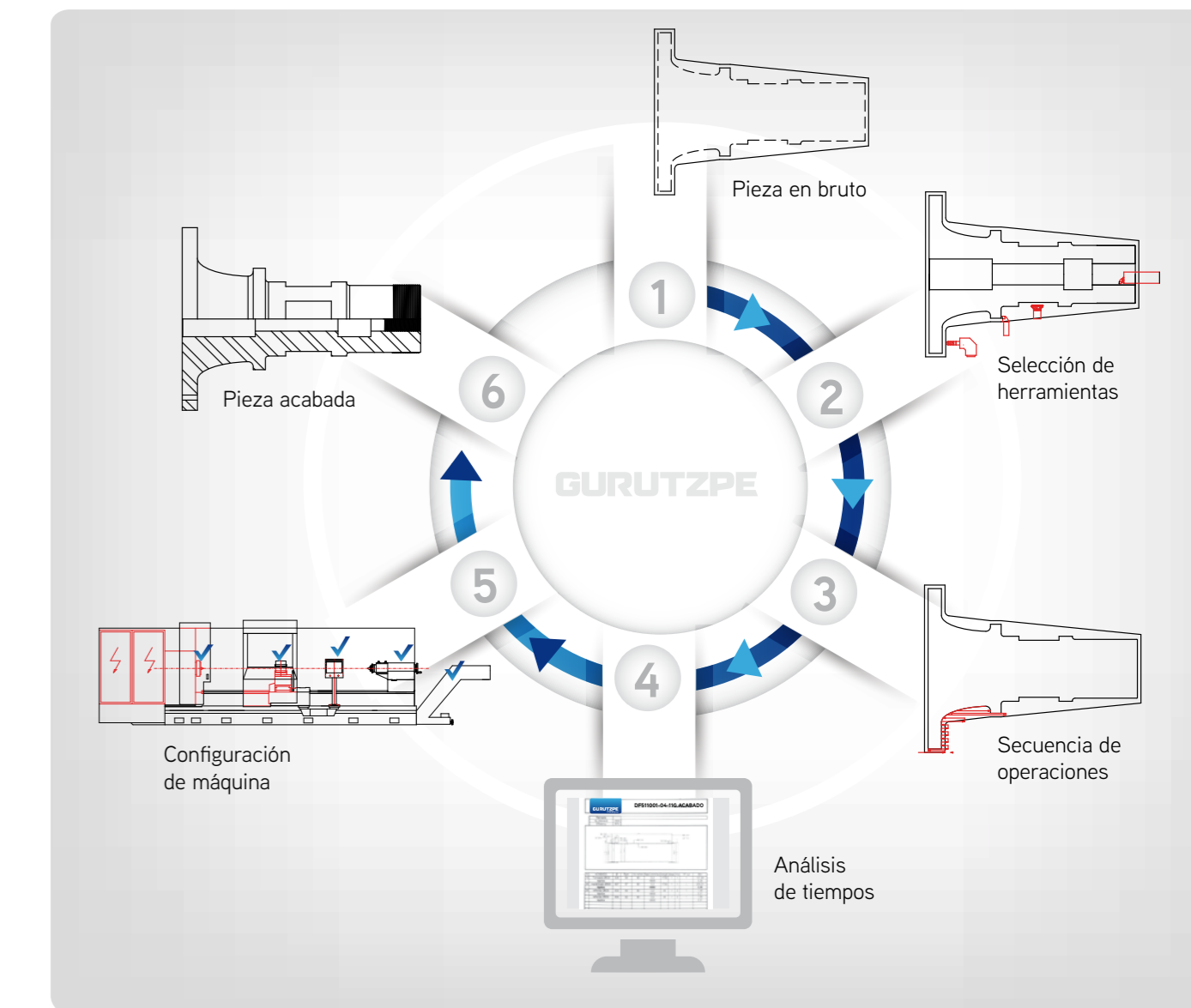

MULTITASKING & 5 AXIS

- Turning
- + Boring
- + Threading
- + Burnishing
- + Measuring
- + Milling
- + Drilling
- + Facing
- + Bottle neck boring
- + Grinding



FAMOC (Fast Machining Operation Change System)

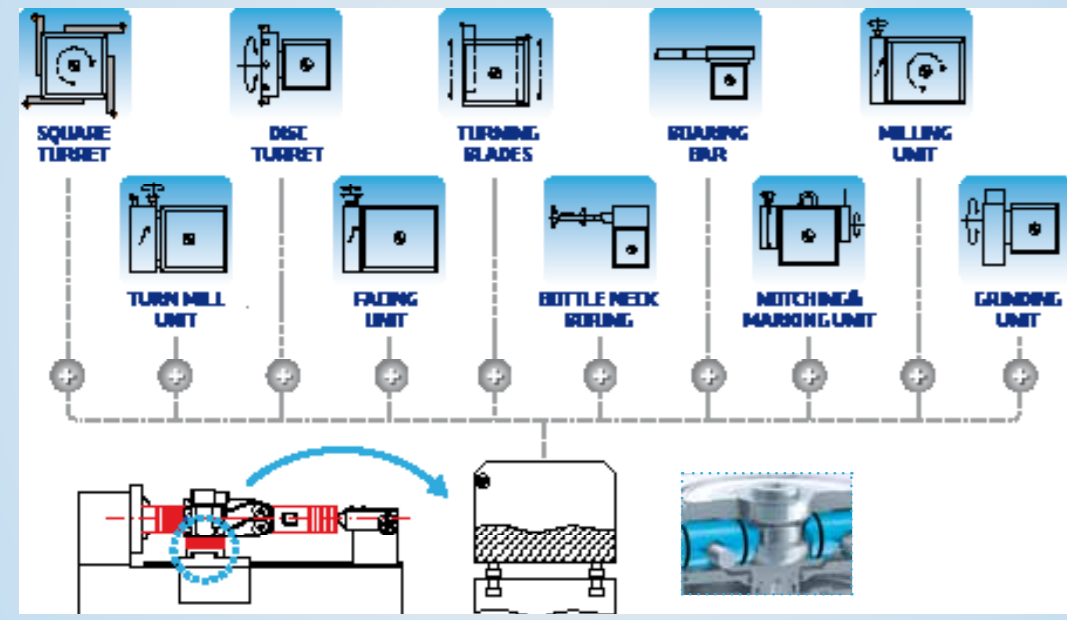

MODEL SELECTION

W _{bc} (t)	S _a (mm)		1000		1300		1600		2000		2500		3000		4000	
	S _c (mm)		700		1000		1300		1700		2100		2500		4000	
5 t	GL 10															
12 t			GL 13 GLX 13													
18 t					GL 16 GLX 16											
25 t							GLX 20									
40 t									GLH 25		GLH 30					
60 t									GLH 25		GLH 30		GLH 40			
90 t											GLH 30		GLH 40			
130 t													GLH 40			

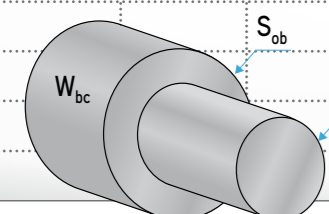

RANGE GL

Extremely robust and reliable two guideway lathes. Monoblock bed in "V" type auto centering double guiding system with a 3rd guide support for the carriage, the GL series achieves the highest rigidity in the guiding, very high material removal capacity, and unsurpassed machining accuracy performance for many years.



SERIE GLX

Four guideway lathes which combine a high working flexibility (crossing steady rests and other accessories...) with a remarkable sturdiness and reliability. Monoblock bed in "V" type auto centering guiding system and a 5th guide support for the carriage to obtain the best results in heavy chip removal and finishing accuracy.

SERIE GLH

Four guideway lathes with open configuration for pieces, to 2500 mm width monoblock bed in "V" type auto centering guiding system and a 5th guide support for the carriage, the GLH series is easy to use and maintain, and achieves the standard quality performance in GURUTZPE.



SERIE GLH 40

Double bed lathes, one for holding the piece (headstock, tailstock and steady rests) and the other for the machining carriages. The longitudinal "V" type guiding and cross anti-yaw effect driving system guarantee the maximum positioning accuracy (< 20 µm) and squareness in regard to the machine axis. User friendly and easy to maintain.

	NOT CROSSING			CROSSING			CROSSING OPEN										
	GL 10	GL13	GL16	GLX13	GLX16	GLX20	GLH25	GLH30	GLH40								
WORKING RANGE	Swing over bed	S _{ob}	mm	Ø 1000	Ø 1300	Ø 1600	Ø 1300	Ø 1600	Ø 2000	Ø 2500	Ø 3000	Ø 4000	Ø 4000				
	Swing over carriage	S _{oc}	mm	Ø 700	Ø 1000	Ø 1200	Ø 1000	Ø 1300	Ø 1700	Ø 2100	Ø 2600	Ø 4000	Ø 4000				
	Distance between centers	L _{bc}	m	≤4	≤8	≤15	≤15	≤15	≤20	≤20	≤25	≤25	≤25				
HEADSTOCK	Motor power S1/S6	P _m	kw	22/28 [28/34]	28/34 [39/48]	39/48 [51/65]	28/34 [39/48]	39/48 [51/65]	71/88 [92/114]	92/114 [113/140]	113/140	226/280	226/280				
	Motor torque S1/S6	T _m	kNm	2,7/3,3 [3,4/4,2]	5,3/6,5 [7,4/9,2]	11,2/13,7 [14,6/18,6]	5,3/6,5 [7,4/9,2]	11,2/13,7 [14,6/18,6]	24,4/30,2 [31,2/38,7]	31,2/38,7 [38,3/47,5]	75,5/93,5	103/127,6	103/127,6				
	Speed range spindle	n _s	rpm	0-1400	0-1200	0-800	0-1200	0-800	0-500	0-500	0-240	0-240	0-240				
	Chuck adapt. DIN 55026			A11	A11	A15	A11	A15	A20	A20	A28	A28	A28				
	Spindle bore	Ø _{sb}	mm	Ø130	Ø150 [Ø360]	Ø110 [Ø550]	Ø150 [Ø360]	Ø110 [Ø550]	Ø110	Ø110	Ø110	Ø110	Ø110				
Shaft diameter at frontal bearing	Ø _{sb}	mm	Ø180	Ø200	Ø203	Ø200	Ø203	Ø254	Ø254	Ø254	Ø254	Ø254					
TAILSTOCK	Workpiece weight bc	W _{bc}	t	5	6/10/12	6/10/12/18	12	18	15/20/25	25/40	60	40	60	90	60	90	130
	Quill	Ø _q	mm	140	140/180/220	140/180/220/280	220	280	220/280/320	320/360	550	360	550	650	550	650	750
	Quill adapt size			Morse 6	ISO 50*	ISO 50*	ISO 50*	ISO 50*	ISO 60*	ISO 60*	ISO 60*	ISO 60*	ISO 60*	ISO 60*	ISO 60*	ISO 60*	ISO 60*
CARRIAGE	Stroke "X" / "Z"		mm	500 / L _{bc} + 50	675 / L _{bc} + 50	800 / L _{bc} + 100	580 / L _{bc} + 50	725 / L _{bc} + 100	900 / L _{bc} + 100	1130 / L _{bc} + 100	1350 / L _{bc} + 100	1750 / L _{bc} + 100	1750 / L _{bc} + 100				
	Force "X" / "Z"	F	kN	10,5 / 17	13,5 / 19,5	19,5 / 29	13,5 / 19,5	19,5 / 29	28 / 35	30,5 / 60	40/75	60/100	60/100				
	Speed "X" / "Z"	v	m/min	8 / 6	8 / 6	8 / 6	8 / 6	8 / 6	8 / 6	8 / 6	8 / 6	8 / 6	8 / 6				
OTHER DATA	Length x Width x Height		m	8,9 (4m) x 2,5 x 2	9,6 (4m) x 2,8 x 2,6	12 (6m) x 3 x 2,8	11,4 (6m) x 2,9 x 2,6	11,8 (6m) x 3,3 x 2,9	14,4 (8m) x 3,5 x 3,2	15 (8m) x 5,6 x 3,5	16,5 (8m) x 7 x 4	18 (8m) x 9,5 x 5,5	18 (8m) x 9,5 x 5,5				
	Center height above ground		mm	1.240	1.675	1.675	1.500	1.690	1.865	2.040	2.290	2.900	2.900				
	Machine weight approx.	W _m	t	12 (4m)	15 (4m)	25 (6m)	20 (6m)	28 (6m)	42 (8m)	50 (8m)	65 (8m)	100 (8m)	100 (8m)				
	Bed width	B _w	mm	680	875	1.090	1.075	1.350	1.650	1.950	2.500	2.500	2x1.950				
	Numerical control			FAGOR / SIEMENS / FANUC			FAGOR / SIEMENS / FANUC			FAGOR / SIEMENS / FANUC			FAGOR / SIEMENS / FANUC				
Acceptance test			DIN 8607			DIN 8607			DIN 8607			DIN 8607					
Acceptance accuracy			ISO 13041			ISO 13041			ISO 13041			ISO 13041					

EXCELLENT PERFORMANCE



TURNING ACCURACY. Machining accuracies that exceed the usual standards required in these machines, reaching roundness of up to 10 µm and surface finish of up to 0,8 Ra. In-process tool and part measurement allows us to guarantee the most demanding targets.



STURDY & RELIABLE. Solid bedway, headstock and tailstock on monoblock GG-30 casting. Maximizing stiffness and damping parameters.



MULTITASK & FAMOC. Incorporating highly-demanding turning operations and other non-traditional lathe operations in a single machine provides great versatility in certain types of parts and offers a significant improvement in productivity.

The turret quick change system FAMOC, provides an easy semi-automatic solution for machining process changes (turning, milling, grinding, boring), without major investment.



"V" GUIDING. Self centering slide guiding system between the hardened & ground cast bed, and the lubricated Biplast top. Best guiding system for turning and grinding, contrasted by the best manufacturers in the world, which GURUTZPE applies to its entire product range.

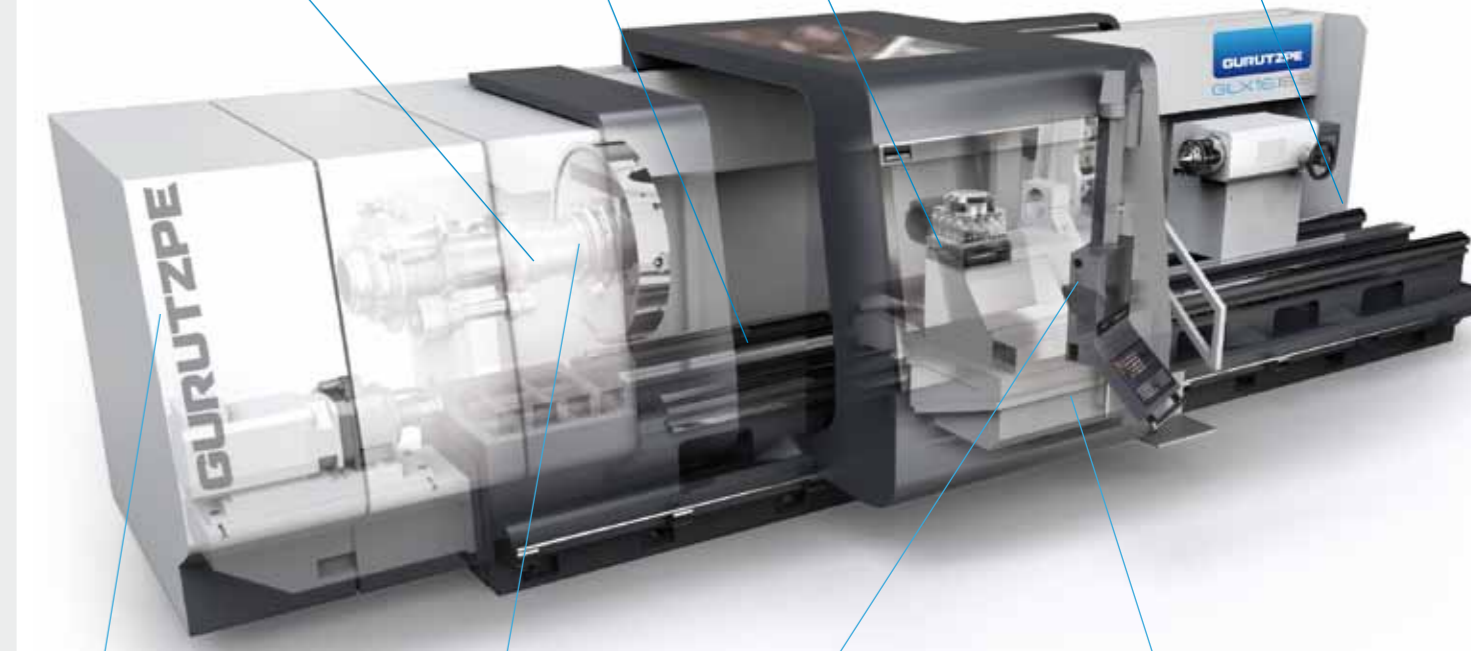

TURNING SOLUTIONS. We want to know your turning challenges at the earliest possible stage of the project, in order to share with you our experience and know-how. Going further into the design of the workpiece, proposing the optimum cutting tools and machining process, and simulating real machine dynamics. Optimized in all aspects and offering the ideal machine, YOUR HIGHEST VALUE SOLUTION. We are committed to your results.



SENSOR & MONITORING. The installation of vibration, temperature, power consumption, etc., sensors in critical areas of the machine allows us to monitor and manage in real time aspects like bearing condition, lubrication system, tool wear, unbalances, etc.

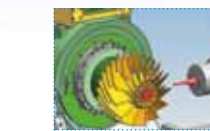

CAM & SIMULATION. From the CAD model of the workpiece, the machining program can be produced a detailed trajectory of the tool and all movements of the machine, optimizing processes and avoiding collisions. This results in substantial increases in productivity.



EASY OPERATION & MAINTENANCE. Our machines are designed by and for people in the workshop. We know that the machines age and warranty period expires, we know that the coolant and chips reach more remote areas. The ease of use and maintenance of the machines are priority assumptions when designing them.

